



CROWN[®] HDPE ELECTRO-FUSION FITTINGS



A QUALITY PRODUCT MANUFACTURED BY :



CROWN ASIA CHEMICALS CORPORATION

Plant : Km. 33, Mc Arthur Highway Tuktukan, Guiguinto, Bulacan : (044) 794-0268 to 70 • Valenzuela Plant & Office: ITC Compound Canumay East, Valenzuela City : 8277-0880 loc. 122 - 132
Quezon City Office: Unit 506 President Tower, 81 Timog Avenue, Quezon City : 8294-2071 loc. 103 - 107



CROWNPIPESPH



CROWN PVC.COM.PH



SALES@CROWN PVC.COM.PH



8277-0880

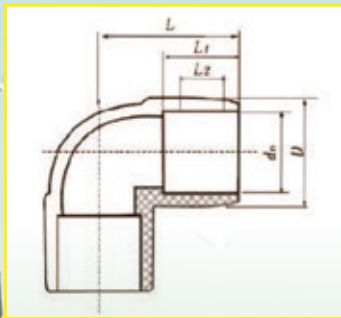

90° ELBOW

DN	D	L	L1	L2
50	65	82	45	20
63	80	85	50	20
75	95	85	55	30
90	110	100	65	35
110	140	115	80	40
140	170	125	80	40
160	200	150	105	45
200	250	170	120	50
225	270	175	110	55
250	292	210	115	65
315	366	235	135	80
355	420	250	140	90
400	473	275	150	100
450	535	295	150	100
500	596	310	160	100

PRESSURE DESCRIPTION 1.6 MPA, 2.0MPA

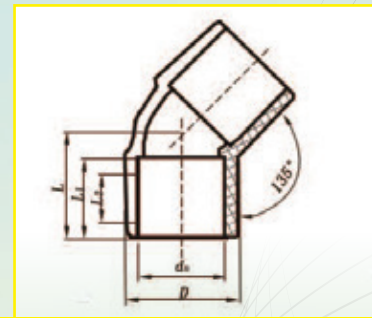

45° ELBOW

DN	D	L	L1	L2
50	65	82	45	20
63	80	85	50	20
75	95	85	55	30
90	110	100	65	35
110	140	115	80	40
140	170	125	80	40
160	200	150	105	45
200	250	170	120	50
225	270	175	110	55
250	292	210	115	65
315	366	235	135	80
355	420	250	140	90
400	473	275	150	100
450	535	295	150	100
500	596	310	160	100

PRESSURE DESCRIPTION 1.6 MPA, 2.0MPA

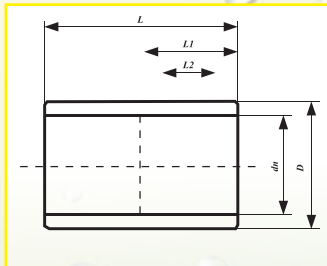

EQUAL COUPLING

DN	D	L	L1	L2
50	65	82	45	20
63	80	85	50	20
75	95	85	55	30
90	110	100	65	35
110	140	115	80	40
140	170	125	80	40
160	200	150	105	45
200	250	170	120	50
225	270	175	110	55
250	292	210	115	65
315	366	235	135	80
355	420	250	140	90
400	473	275	150	100
450	535	295	150	100
500	596	310	160	100
560	665	340	160	140
630	710	420	200	180

PRESSURE DESCRIPTION 1.6 MPA, 2.0MPA

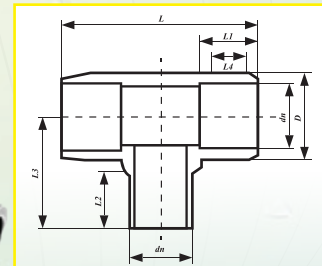

EQUAL TEE

DN	D	DN	L	L1	L2	L3	L4
50	65	50	150	45	45	90	20
63	80	63	175	50	50	105	20
75	95	75	205	55	55	120	30
90	110	90	230	65	65	140	35
110	140	110	265	75	75	160	40
140	160	140	320	80	80	180	40
160	200	160	366	95	95	215	45
200	250	200	435	105	105	250	50
225	250	225	460	110	110	255	55
250	296	250	485	115	115	285	65
315	373	315	575	135	135	350	80
355	420	355	660	140	140	375	90
400	473	400	740	150	150	425	100
450	535	450	785	155	155	460	100
500	595	500	845	160	160	490	100

PRESSURE DESCRIPTION 1.6 MPA, 2.0MPA

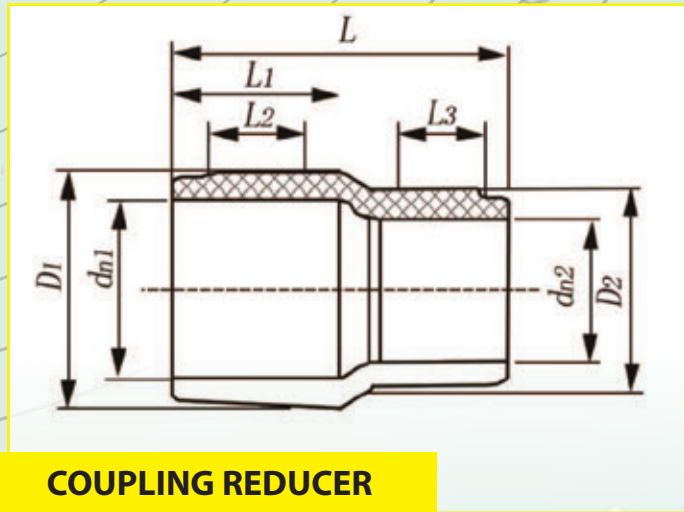

COUPLING REDUCER

DN	D1	DN2	D2	L	L1	L2	L3
63	80	50	65	120	50	30	30
75	95	50	65	135	55	35	35
75	95	63	80	135	55	35	35
90	110	50	65	155	65	40	40
90	110	63	80	155	65	40	40
90	110	75	95	175	65	40	40
110	140	50	65	160	75	50	50
110	140	63	80	160	75	50	50
110	140	73	95	165	75	50	50
110	140	90	110	175	75	50	50
140	160	90	110	190	90	55	55
140	160	110	140	190	90	55	55
160	200	110	110	230	75	70	70
160	200	90	140	230	95	70	70
200	250	110	140	290	105	55	55
200	250	160	200	250	105	60	60
225	260	110	140	260	115	50	50
225	260	140	140	260	115	50	50
225	260	160	200	260	115	50	50
225	260	200	250	260	115	50	50
250	296	110	140	280	120	50	50
250	296	140	460	280	120	50	50
250	296	160	200	280	120	50	50
250	296	200	250	280	120	50	50
250	296	225	260	280	120	50	70
315	373	110	140	310	140	70	70
315	373	140	160	310	140	70	70
315	373	160	200	310	140	70	75
315	373	200	250	310	140	70	75
315	373	225	260	310	140	70	80
315	373	250	296	310	140	70	70
355	420	110	140	330	150	80	70
355	420	140	160	330	150	80	70

DN	D1	DN2	D2	L	L1	L2	L3
355	420	160	200	330	150	80	70
355	420	200	250	330	150	80	70
355	420	225	260	330	150	80	70
355	420	250	296	330	150	80	70
355	420	315	373	330	150	80	70
400	468	110	146	340	160	85	70
400	468	140	160	340	160	85	70
400	468	160	200	340	160	85	70
400	468	200	250	340	160	85	75
400	468	225	260	340	160	85	75
400	468	250	296	340	160	85	80
400	468	315	373	340	160	85	90
400	468	355	420	340	160	85	95
450	535	110	140	360	170	90	70
450	535	140	160	360	170	90	70
450	535	160	160	360	180	90	70
450	535	200	200	360	180	90	75
450	535	225	225	360	180	90	75
450	535	250	250	360	180	90	80
450	535	315	315	360	180	90	90
450	535	355	355	360	180	90	95
450	535	400	400	360	180	90	100
500	590	110	110	380	180	100	70
500	590	140	140	380	180	100	70
500	590	160	160	380	180	100	70
500	590	200	200	380	180	100	75
500	590	225	225	380	180	100	75
500	590	250	250	380	180	100	80
500	590	315	315	380	180	100	90
500	590	355	355	380	180	100	95
500	590	400	400	380	180	100	100
500	590	450	450	380	180	100	110

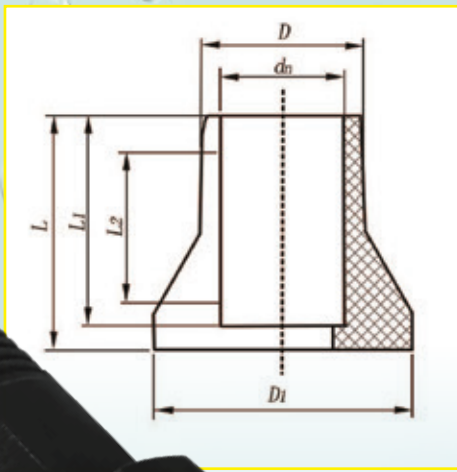
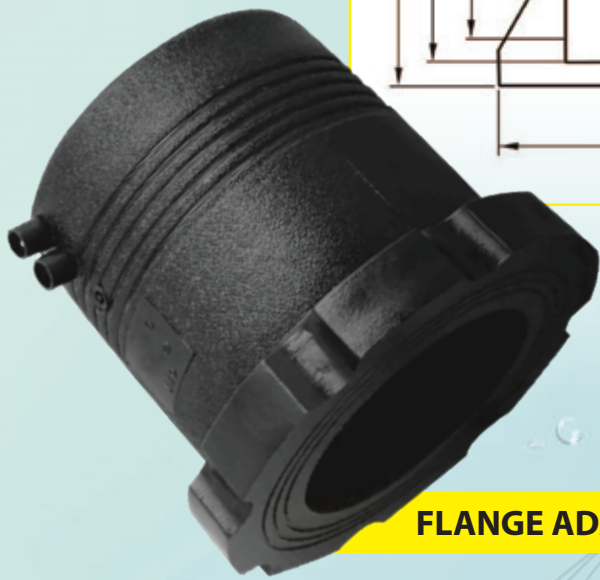

FLANGE ADAPTER

DN	D	D1	L	L1	L2
50	65	90	115	115	40
63	80	105	120	110	40
75	95	125	130	125	70
90	110	140	145	140	70
110	140	150	150	140	75
140	165	190	155	145	80
160	190	215	160	150	85
200	235	270	180	165	95
225	255	315	175	160	60
250	280	325	130	110	60
315	350	380	135	115	60
355	380	450	170	155	60
400	435	495	160	140	65
450	480	560	190	180	100
500	540	580	230	210	120
560	610	650	220	220	130
630	680	720	250	250	150

PRESSURE DESCRIPTION 1.6 MPA, 2.0MPA

ELECTRO-FUSION MACHINE



PRINTER
(Optional)



SCANNER
(Optional)



SCRAPER
(Standard)



ELECTRIC MELTING
WELDING MACHINE
HEAD
(Standard)

MODEL	200	315	500
Welding Range	20 - 200	20 - 315	20 - 500
Input Voltage	AC 220v ±20% 50-60hz Single	AC 220v ±20% 50-60hz Single	AC 220v ±20% 50-60hz Single
Input Power	2.5 kw	3.5 kw	5.5 kw
Output Voltage	AC10 - 55v	AC10 - 65v	AC10 - 90v
Output Current	50a	60a	80a
Working Environment	-15 - 45°C Relative Humidity 80%	-15 - 45°C Relative Humidity 80%	-15 - 45°C Relative Humidity 80%
Protection Level	IP54	IP54	IP54
Load	60%	60%	60%
Package Size	40 * 27 * 30	53* 36 * 30	53* 36 * 30
Weight	19	25	32

A QUALITY PRODUCT MANUFACTURED BY :



CROWN ASIA CHEMICALS CORPORATION

Plant : Km. 33, Mc Arthur Highway Tuktukan, Guiguinto, Bulacan : (044) 794-0268 to 70 • Valenzuela Plant & Office: ITC Compound Canamay East, Valenzuela City : 8277-0880 loc. 122 - 132
Quezon City Office: Unit 506 President Tower, 81 Timog Avenue, Quezon City : 8294-2071 loc. 103 - 107



CROWNPIPEPH



CROWN PVC.COM.PH



SALES@CROWN PVC.COM.PH



8277-0880